



PHONE: (705) 386-0757
FAX: (705) 386-0915
TOLL FREE: 1-800-421-1406

BOX 509, SOUTH RIVER, ONTARIO P0A 1X0



FOLDING RECLINER

Directions - Mode d'emploi

Assembly

Remove all parts from the box. You should have 1 seat assembly, 1 back assembly, 2 arms, 2 legs and 2 leg supports.

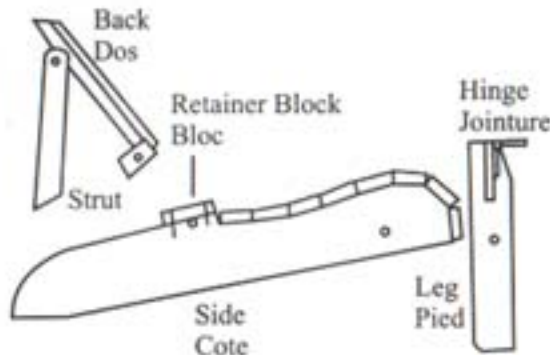

Remove rear screws from retainer blocks. Place the doweling pegs at the bottom of the back assembly, into the slot in the seat assembly by rotating the retainer blocks out of the way. Reinstall screws into the rear hole of each retainer block to secure back assembly. To attach legs, push carriage bolts through hole in each side of seat assembly and replace washers and wing nut on inside. The cutout on the top of the legs and the hinges face forward.

Assemblage

Enlever tous les morceaux de la boîte. Vous devez avoir l'ensemble dos, 2 bras, 2 pieds et 2 supports de pieds.

Enlever les visses arrières des blocs. Placer les batonnets au bas de l'ensemble dos dans le creux de l'ensemble siège en tournant les blocs pour les enlever. Re-installer les visses dans le trou arrière de chaque bloc pour rendre l'ensemble dos solide. Pour attacher les pieds, pousser les boulons dans les trous de chaque côté de l'ensemble siège et replacer les joints et les visses papillon sur l'intérieur. Les découpures sur le dessus des pieds et les jointures font face vers l'avant.

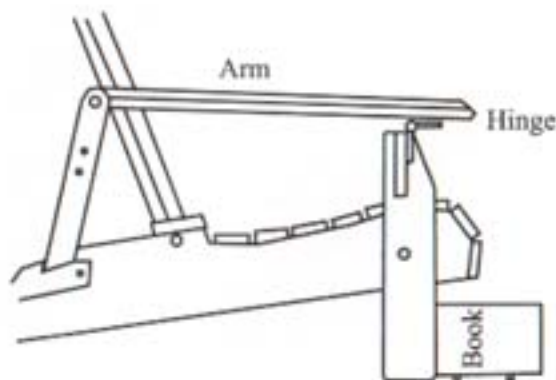

Arms

Screw large screw (in back of arm) into the hole in the dowel on each side of the upper back support (only tighten until arm touches the doweling).

To attach the hinges onto the underside of the arms you must first put the back in the most upright of the 3 positions. Next ensure that the legs are vertical by placing a square (or a book does nicely) against the side of the leg and attach the 3 hinge screws (short) to the underside of the arm, allowing the inside edge of the arm to overlap the inside of the leg by 1/2" / 12 mm (or a finger width or so.)

Bras

Visser la grande visse (à l'arrière du bras) dans le trou du batonnet sur chaque côté du support supérieur du dos (serrer jusqu'à ce que le bras touche les batonnets).